

## N18-150

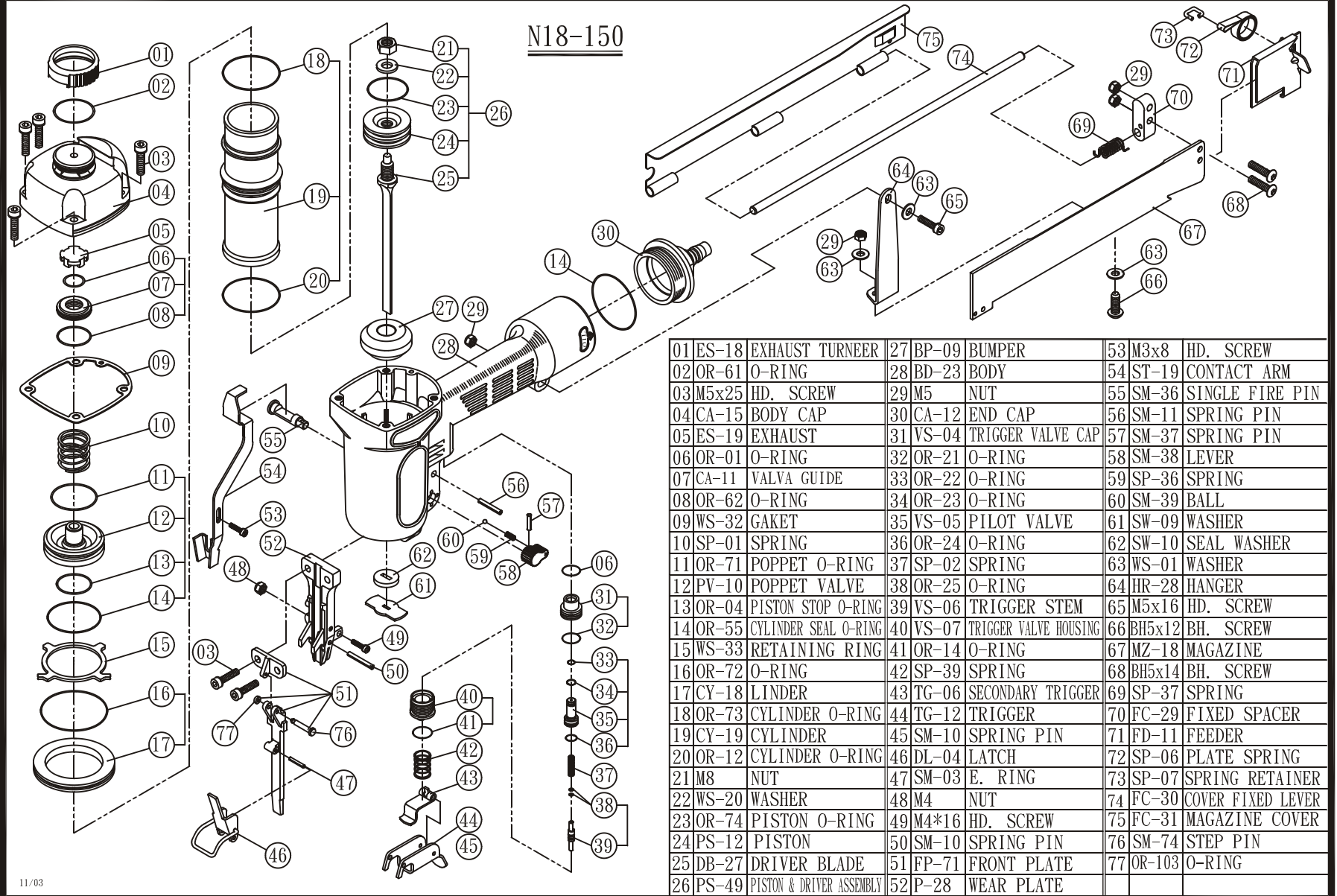

01	ES-18	EXHAUST TURNER	27	BP-09	BUMPER	53	M3x8	HD. SCREW
02	OR-61	O-RING	28	BD-23	BODY	54	ST-19	CONTACT ARM
03	M5x25	HD. SCREW	29	M5	NUT	55	SM-36	SINGLE FIRE PIN
04	CA-15	BODY CAP	30	CA-12	END CAP	56	SM-11	SPRING PIN
05	ES-19	EXHAUST	31	VS-04	TRIGGER VALVE CAP	57	SM-37	SPRING PIN
06	OR-01	O-RING	32	OR-21	O-RING	58	SM-38	LEVER
07	CA-11	VALVA GUIDE	33	OR-22	O-RING	59	SP-36	SPRING
08	OR-62	O-RING	34	OR-23	O-RING	60	SM-39	BALL
09	WS-32	GAKET	35	VS-05	PILOT VALVE	61	SW-09	WASHER
10	SP-01	SPRING	36	OR-24	O-RING	62	SW-10	SEAL WASHER
11	OR-71	POPPET O-RING	37	SP-02	SPRING	63	WS-01	WASHER
12	PV-10	POPPET VALVE	38	OR-25	O-RING	64	HR-28	HANGER
13	OR-04	PISTON STOP O-RING	39	VS-06	TRIGGER STEM	65	M5x16	HD. SCREW
14	OR-55	CYLINDER SEAL O-RING	40	VS-07	TRIGGER VALVE HOUSING	66	BH5x12	BH. SCREW
15	WS-33	RETAINING RING	41	OR-14	O-RING	67	MZ-18	MAGAZINE
16	OR-72	O-RING	42	SP-39	SPRING	68	BH5x14	BH. SCREW
17	CY-18	LINDER	43	TG-06	SECONDARY TRIGGER	69	SP-37	SPRING
18	OR-73	CYLINDER O-RING	44	TG-12	TRIGGER	70	FC-29	FIXED SPACER
19	CY-19	CYLINDER	45	SM-10	SPRING PIN	71	FD-11	FEEDER
20	OR-12	CYLINDER O-RING	46	DL-04	LATCH	72	SP-06	PLATE SPRING
21	M8	NUT	47	SM-03	E. RING	73	SP-07	SPRING RETAINER
22	WS-20	WASHER	48	M4	NUT	74	FC-30	COVER FIXED LEVER
23	OR-74	PISTON O-RING	49	M4*16	HD. SCREW	75	FC-31	MAGAZINE COVER
24	PS-12	PISTON	50	SM-10	SPRING PIN	76	SM-74	STEP PIN
25	DB-27	DRIVER BLADE	51	FP-71	FRONT PLATE	77	OR-103	O-RING
26	PS-49	PISTON & DRIVER ASSEMBLY	52	P-28	WEAR PLATE			